

**CLASS X (2020-21)**  
**MATHEMATICS STANDARD (041)**  
**SAMPLE PAPER-09**

**Time : 3 Hours**

**Maximum Marks : 80**

**General Instructions :**

1. This question paper contains two parts A and B.
2. Both Part A and Part B have internal choices.

**Part-A :**

1. It consists of two sections- I and II.
2. Section I has 16 questions. Internal choice is provided in 5 questions.
3. Section II has four case study-based questions. Each case study has 5 case-based sub-parts. An examinee is to attempt any 4 out of 5 sub-parts.

**Part-B :**

1. Question no. 21 to 26 are very short answer type questions of 2 mark each.
2. Question no. 27 to 33 are short answer type questions of 3 marks each.
3. Question no. 34 to 36 are long answer type questions of 5 marks each.
4. Internal choice is provided in 2 questions of 2 marks, 2 questions of 3 marks and 1 question of 5 marks.

## Part - A

### Section - I

1. Write whether rational number  $\frac{7}{75}$  will have terminating decimal expansion or a non-terminating decimal.

**Ans :** [Board Term-1 2017, SQP]

We have  $\frac{7}{75} = \frac{7}{3 \times 5^2}$

Since denominator of given rational number is not of form  $2^m \times 5^n$ , Hence, It is non-terminating decimal expansion.

**or**

Find HCF of the numbers given below:  
 $k, 2k, 3k, 4k$  and  $5k$ , where  $k$  is a positive integer.

**Ans :** [Board Term-1 2015]

Here we can see easily that  $k$  is common factor between all and this is highest factor Thus HCF of  $k, 2k, 3k, 4k$  and  $5k$ , is  $k$ .

2. A fraction becomes 4 when 1 is added to both the numerator and denominator and it becomes 7 when 1 is subtracted from both the numerator and denominator. What is the numerator of the given fraction ?

**Ans :**

Let the fraction be  $\frac{x}{y}$ ,

$$\frac{x+1}{y+1} = 4$$

$$\Rightarrow x = 4y + 3 \quad \dots(1)$$

and  $\frac{x-1}{y-1} = 7$

$$\Rightarrow x = 7y - 6 \quad \dots(2)$$

Solving (1) and (2), we have  $x = 15, y = 3$ ,

3.  $\Delta ABC$  is an equilateral triangle with each side of length  $2p$ . If  $AD \perp BC$  then what is the value of  $AD$  ?

**Ans :**

We have  $AB = BC = CA = 2p$   
and  $AD \perp BC$

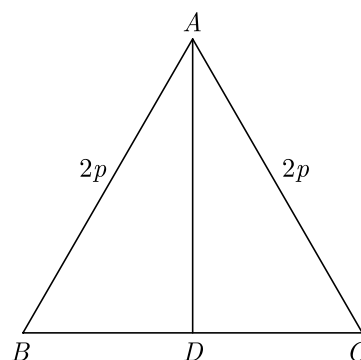

In  $\Delta ADB$ ,  $AB^2 = AD^2 + BD^2$   
 $(2p)^2 = AD^2 + p^2$   
 $AD^2 = \sqrt{3} p$

4. If the point  $P(k, 0)$  divides the line segment joining the points  $A(2, -2)$  and  $B(-7, 4)$  in the ratio  $1 : 2$ , then what is the value of  $k$ ?

**Ans :** [Board 2020 Delhi Standard]

As per question statement figure is shown below.

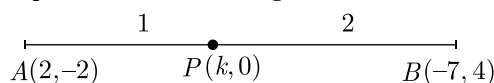

$$k = \frac{1(-7) + 2(2)}{1 + 2} \quad \left(x = \frac{mx_2 + nx_1}{m + n}\right)$$

$$= \frac{-7 + 4}{3} = \frac{-3}{3} = -1$$

Thus  $k = -1$



or

Find the coordinates of a point  $A$  on  $y$ -axis, at a distance of 4 units from  $x$ -axis and below it.

**Ans :** [Board 2020 Delhi Basic]

Because the point is 4 units down the  $x$ -axis i.e., co-ordinate is  $-4$  and on  $y$ -axis abscissa is 0. So, the coordinates of point  $A$  is  $(0, -4)$ .



5. If  $\sin \theta + \cos \theta = \sqrt{2} \cos \theta$ , ( $\theta \neq 90^\circ$ ) then what is the value of  $\tan \theta$  ?

**Ans :** [Board 2020 SQP Standard]

We have  $\sin \theta + \cos \theta = \sqrt{2} \cos \theta$   
Dividing both sides by  $\cos \theta$ , we get



$$\frac{\sin \theta}{\cos \theta} + \frac{\cos \theta}{\cos \theta} = \sqrt{2} \frac{\cos \theta}{\cos \theta}$$

$$\tan \theta + 1 = \sqrt{2}$$

$$\tan \theta = \sqrt{2} - 1$$

6. If  $4 \tan \theta = 3$ , then find  $\left( \frac{4 \sin \theta - \cos \theta}{4 \sin \theta + \cos \theta} \right)$ .

**Ans :**



We have,  $4 \tan \theta = 3$

$$\tan \theta = \frac{3}{4} \quad \dots(i)$$

$$\frac{4 \sin \theta - \cos \theta}{4 \sin \theta + \cos \theta} = \frac{4 \frac{\sin \theta}{\cos \theta} - 1}{4 \frac{\sin \theta}{\cos \theta} + 1} = \frac{4 \tan \theta - 1}{4 \tan \theta + 1}$$

$$= \frac{4 \left( \frac{3}{4} \right) - 1}{4 \left( \frac{3}{4} \right) + 1} = \frac{3 - 1}{3 + 1} = \frac{2}{4} = \frac{1}{2}$$

Thus (c) is correct option.

7. An observer, 1.5 m tall is 20.5 away from a tower 22 m high, then what is the angle of elevation of the top of the tower from the eye of observer?

**Ans :**

Let  $BE = 22$  m be the height of the tower and  $AD = 1.5$  m be the height of the observer. The point  $D$  be the observer's eye. We draw  $DC \parallel AB$  as shown below.

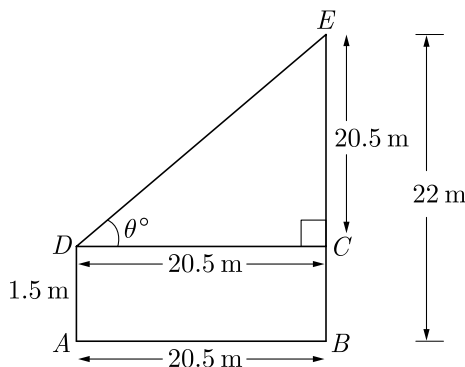

Then,  $AB = 20.5 \text{ m} = DC$

and  $EC = BE - BC = BE - AD$   
 $= 22 - 1.5 = 20.5 \text{ m}$



[ $BC = AD$ ]

Let  $\theta$  be the angle of elevation make by observer's eye to the top of the tower i.e.  $\angle DCE$ ,

$$\tan \theta = \frac{P}{B} = \frac{CE}{DC} = \frac{20.5}{20.5}$$

$$\tan \theta = 1$$

$$\tan \theta = \tan 45^\circ \Rightarrow \theta = 45^\circ$$

or

A 6 m high tree cast a 4 m long shadow. At the same time, a flag pole cast a shadow 50 m long. How long is the flag pole?

**Ans :**

Let  $AB$  be height of tree and  $BC$  its shadow.

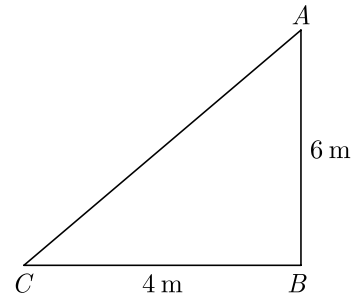

Again, let  $PQ$  be height of pole and  $QR$  be its shadow. At the same time, the angle of elevation of tree and poles are equal i.e.  $\Delta ABC \sim PQR$

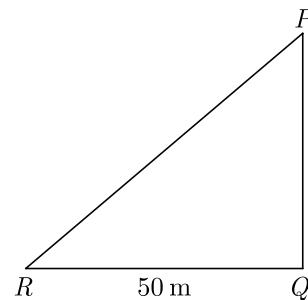

Thus

$$\frac{AB}{BC} = \frac{PQ}{QR}$$

$$\frac{6}{4} = \frac{PQ}{50}$$

$$PQ = \frac{50 \times 6}{4} = 75 \text{ m}$$

8. Two concentric circles of radii  $a$  and  $b$  where  $a > b$ , Find the length of a chord of the larger circle which touches the other circle.

**Ans :**

In  $\Delta OAL$ ,

$$OA^2 = OL^2 + AL^2$$

$$a^2 = OL^2 + b^2$$

$$OL = \sqrt{a^2 - b^2}$$

Length of chord,

$$2AL = 2\sqrt{a^2 - b^2}$$

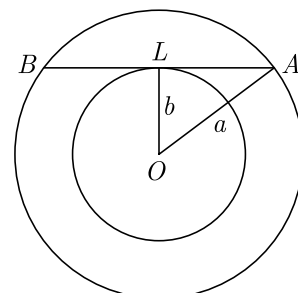

or

In the given figure, a circle touches all the four sides of quadrilateral  $ABCD$  with  $AB = 6$  cm,  $BC = 7$  cm and  $CD = 4$  cm, then what is the length of  $AD$  ?

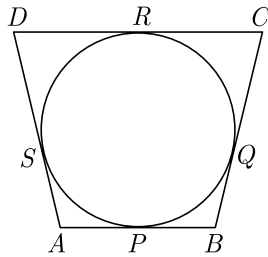

Ans :

Four sides of a quadrilateral  $ABCD$  are tangent to a circle.

$$AB + CD = BC + AD$$

$$6 + 4 = 7 + AD$$

$$AD = 10 - 7 = 3 \text{ cm}$$

9. To divide a line segment  $AB$  in the ratio 2:5, a ray  $AX$  is drawn such that  $\angle BAX$  is acute. Then points are marked at equal intervals on  $AX$ . What is the minimum number of these points ?

Ans : [Board Term-2, 2012]

Minimum number of points marked on  $AX$  are  $2 + 5 = 7$ .



or

To divide the line segment  $AB$  in the ratio 2 : 3, a ray  $AX$  is drawn such that  $\angle BAX$  is acute,  $AX$  is then marked at equal intervals. Find minimum number of these marks.

Ans : [Board Term-2 2012]

Minimum number of points marked on  $AX$  are  $2 + 3 = 5$ .



10. In the given figure,  $AB$  is the diameter where  $AP = 12$  cm and  $PB = 16$  cm. Taking the value of  $\pi$  as 3, find the perimeter of the shaded region.

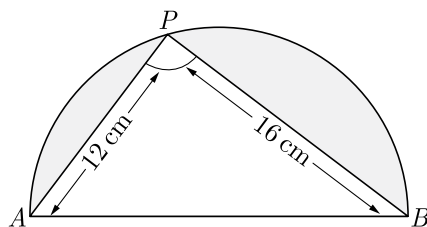

Ans : [Board Term-2 2012]

From Pythagoras theorem we have

$$AB = \sqrt{(16)^2 + (12)^2}$$

$$= \sqrt{256 + 144}$$

$$= \sqrt{400} = 20 \text{ cm}$$



Radius of circle = 10 cm.

Perimeter of shaded region

$$\pi r + AP + PB = 3 \times 10 + 12 + 16$$

$$= 30 + 12 + 16 = 58 \text{ cm}$$

11. Find the area (in  $\text{cm}^2$ ) of the circle that can be inscribed in a square of side 8 cm.

Ans : [board Term-2, 2012 Set (28, 32, 33)]

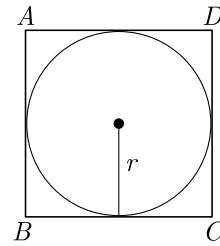

Side of square = diameter of circle = 8 cm

$$\text{Radius of circle, } r = \frac{8}{2} = 4 \text{ cm}$$

$$\text{Area of circle, } \pi r^2 = \pi \times 4 \times 4 = 16\pi \text{ cm}^2$$

12. Consider the following frequency distribution of the heights of 60 students of a class

Height (in cm)	150-155	155-160	160-165	165-170	170-175	175-180
Number of students	15	13	10	8	9	5

What is the upper limit of the median class in the given data?

Ans : [Board 2020 SQP Standard]

We prepare the following cumulative table

Height $x$ (in cm)	Number of Students ( $f$ )	$cf$
150-155	15	15
155-160	13	28
160-165	10	38
165-170	08	46
170-175	09	55
175-180	08	63
	$N = 63$	

$$\text{We have, } N = 63; \frac{N}{2} = \frac{63}{2} = 31.5$$

The cumulative frequency just greater than  $\frac{N}{2}$  is 38 and the corresponding class is 160-165. Thus upper limit is 165.



13. If  $x_i$ 's are the mid-points of the class intervals of grouped data,  $f_i$ 's are the corresponding frequencies and  $\bar{x}$  is the mean, then find  $\sum(f_i x_i - \bar{x})$ .

Ans :

$$\sum(f_i x_i - \bar{x}) = \sum f_i x_i - \sum \bar{x} = \sum f_i x_i - n\bar{x}$$

$$= \sum f_i x_i - \sum f_i \bar{x} = 0 \quad \left( \bar{x} = \frac{\sum f_i x_i}{n} \right)$$



14. Out of one digit prime numbers, one number is selected at random. What is the probability of selecting an even number?

**Ans :**

One digit prime numbers are 2, 3, 5, 7. Out of these numbers, only the number 2 is even.

$$n(S) = 4$$

$$n(E) = 1$$

Required probability,

$$P(E) = \frac{n(E)}{n(S)} = \frac{1}{4}$$



15. Find the probability of an impossible event.

**Ans :** [Board Term-2, 2012]

Probability of impossible event is 0.



16. A number is selected at random from 1 to 30. Find the probability that it is a prime number.

**Ans :** [Board Term-2, 2014]

Number of possible outcomes,

$$n(S) = 30$$

Prime numbers are 2,

3, 5, 7, 11, 13, 17, 19, 23 and 29.

Number of favourable outcomes,  $n(E) = 10$

$$P(\text{prime}), P(E) = \frac{n(E)}{n(S)} = \frac{10}{30} = \frac{1}{3}$$



## Section II

Case study-based questions are compulsory. Attempt any 4 sub parts from each question. Each question carries 1 mark.

17. For a jewellery metal box to satisfy certain requirements, its length must be three meter greater than the width, and its height must be two meter less than the width.



- (i) If width is taken as  $x$ , which of the following polynomial represent volume of box ?

- (a)  $x^2 - 5x - 6$
- (b)  $x^3 + x^2 - 6x$
- (c)  $x^3 - 6x^2 - 6x$
- (d)  $x^2 + x - 6$



- (ii) Which of the following polynomial represent the area of metal sheet used to make box ?

- (a)  $x^2 - 5x - 6$
- (b)  $6x^2 + 4x - 12$
- (c)  $x^3 - 6x^2 - 6x$
- (d)  $6x^2 + 3x - 4$

- (iii) If it must have a volume of  $18 \text{ in}^3$ , what must be its length ?

- (a) 6 in
- (b) 3 in
- (c) 4 in
- (d) 2 in

- (iv) At a volume of  $18 \text{ in}^3$ , what must be its height ?

- (a) 1 in
- (b) 3 in
- (c) 2 in
- (d) 4 in

- (v) If box is made of a metal sheet which cost is 10 rs per  $\text{in}^2$ , what is the cost of metal ?

- (a) Rs 540
- (b) Rs 1080
- (c) Rs 270
- (d) Rs 340

**Ans :**

(i) 
$$V(x) = x(x+3)(x-2)$$

$$= x(x^2 + x - 6) = x^3 + x^2 - 6x$$

Thus (d) is correct option.

(ii) 
$$S(x) = 2(LW + WH + HL)$$

$$= 2[x(x+3) + (x+3)(x-2) + x(x-2)]$$

$$= 2[x^2 + 3x + x^2 + x - 6 + x^2 - 2x]$$

$$= 2(3x^2 + 2x - 6)$$

$$= 6x^2 + 4x - 12$$

Thus (b) is correct option.

(iii) We have 
$$V(x) = x^3 + x^2 - 6x$$

$$18 = x^3 + x^2 - 6x$$

$$x^3 + x^2 - 6x - 18 = 0$$

$$x^3 - 3x^2 + 4x^2 - 12x + 6x - 18 = 0$$

$$x^2(x-3) + 4x(x-3) + 6(x-3) = 0$$

$$(x-3)(x^2 + 4x + 6) = 0$$

Thus width is 3 in.

Length =  $x + 3 = 6$  in

Thus (a) is correct option.

(iv) Height =  $x - 2 = 3 - 2 = 1$  in

Thus (a) is correct option.

(v) 
$$S(x) = 6x^2 + 4x - 12$$

$$= 6 \times 3 \times 3 + 4 \times 3 - 12 = 54 \text{ in}^2$$

$$C = 10 \times 54 = 540 \text{ ₹}$$

Thus (a) is correct option.

18. Raju and his classmates planned a picnic in zoo. The total budget for picnic was Rs 2000 but 5 students failed to attend the picnic and thus the contribution for each student was increased by Rs 20.



The expense of different item was as follows.

S. No.	Article	Cost per student
1	Entry ticket	Rs 5
2	Coffee	Rs 10
3	Food	Rs 25
4	Travelling cost	Rs 50
5	Ice-cream	Rs 15



The park can be modelled as a coordinate systems given below.

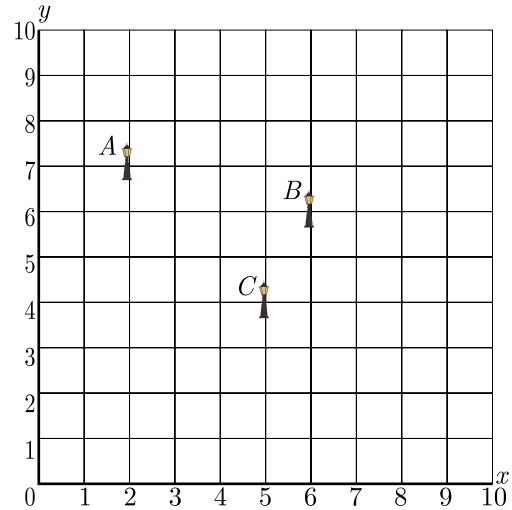

- (i) If  $x$  is the number of students planned for picnic, which is the correct quadratic equation that describe the situation.
  - (a)  $x^2 - 5x - 500 = 0$
  - (b)  $x^2 + 4x - 400 = 0$
  - (c)  $x^2 + 5x - 500 = 0$
  - (d)  $x^2 - 4x + 400 = 0$
- (ii) What is the number of students planned for picnic ?
  - (a) 30
  - (b) 40
  - (c) 25
  - (d) 20
- (iii) What is the number of students who attended the picnic?
  - (a) 20
  - (b) 40
  - (c) 15
  - (d) 25
- (iv) What is the total expanse for this picnic ?
  - (a) Rs 1500
  - (b) Rs 2000
  - (c) Rs 1000
  - (d) Rs 2100
- (v) How much money they spent for travelling ?
  - (a) Rs 500
  - (b) Rs 1000
  - (c) Rs 800
  - (d) Rs 3750

Ans :

(i) We have  $\frac{2000}{x} + 20 = \frac{2000}{x-5}$   
 $2000(x-5) + 20x(x-5) = 2000x$   
 $-10000 + 20x^2 - 100x = 0$   
 $x^2 - 5x - 500 = 0$

Thus (a) is correct option.

(ii) We have  $x^2 - 5x - 500 = 0$   
 $x^2 - 25x + 20x - 500 = 0$   
 $x(x-25) + 20(x-25) = 0$   
 $(x-25)(x+20) = 0$

$x = 25, -20$

Thus (c) is correct option.

(iii)  $x = 25 - 5 = 20$  Students attended picnic

Thus (a) is correct option.

(iv) Expanse per student =  $5 + 10 + 25 + 50 + 15 = 105$

Total expanse,  $105 \times 20 = 2100$

Thus (d) is correct option.

(v) Expanse on travelling  $50 \times 20 = 1000$

Thus (b) is correct option.

19. Resident Welfare Association (RWA) of a Gulmohar Society in Delhi have installed three electric poles  $A$ ,  $B$  and  $C$  in a society's common park. Despite these three poles, some parts of the park are still in dark. So, RWA decides to have one more electric pole  $D$  in the park.

On the basis of the above information, answer any four of the following questions:

- (i) What is the position of the pole  $C$ ?
  - (a) (4, 5)
  - (b) (5, 4)
  - (c) (6, 5)
  - (d) (5, 6)
- (ii) What is the distance of the pole  $B$  from the corner  $O$  of the park ?
  - (a)  $6\sqrt{2}$  units
  - (b)  $3\sqrt{2}$  units
  - (c)  $6\sqrt{3}$  units
  - (d)  $3\sqrt{3}$  units
- (iii) Find the position of the fourth pole  $D$  so that four points  $A$ ,  $B$ ,  $C$  and  $D$  form a parallelogram .
  - (a) (5, 2)
  - (b) (1, 5)
  - (c) (1, 4)
  - (d) (2, 5)
- (iv) What is the distance between poles  $A$  and  $C$  ?
  - (a)  $6\sqrt{2}$  units
  - (b)  $3\sqrt{2}$  units
  - (c)  $6\sqrt{3}$  units
  - (d)  $3\sqrt{3}$  units
- (v) What is the distance between poles  $B$  and  $D$ ?
  - (a)  $2\sqrt{3}$  units
  - (b)  $\sqrt{28}$  units
  - (c)  $6\sqrt{3}$  units
  - (d)  $\sqrt{26}$  units

Ans :

(i) From the given digram we can easily get that position of the pole  $C$  (5, 4). Thus (b) is correct option.

(ii) Coordinates of  $B$  are (6, 6).

Distance from origin =  $\sqrt{(6-0)^2 + (6-0)^2}$   
 $= \sqrt{36 + 36} = 6\sqrt{2}$  units

Thus (a) is correct option.

(iii) If  $ABCD$  is a parallelogram, the diagonals bisects each other. Here  $AC$  and  $BD$  are diagonals.

Mid-point of  $AC = \left(\frac{2+5}{2}, \frac{7+4}{2}\right) = (3.5, 5.5)$

Now, mid-point of diagonal,  $BD$  will be  $(3.5, 5.5)$  also.  
Let, the coordinates of  $D$  be  $(x, y)$

Now  $\frac{6+x}{2} = 3.5$  and  $\frac{6+y}{2} = 5.5$

$x = 1$  and  $y = 5$

Thus (b) is correct option.

(iv) Coordinates of  $A$  are  $(2, 7)$  and coordinates of  $C$  are  $(5, 4)$ .

Distance between pole  $A$  and  $C$ ,

$$AC = \sqrt{(5-2)^2 + (4-7)^2}$$

$$= \sqrt{9+9} = 3\sqrt{2} \text{ units}$$

Thus (b) is correct option.

(v) Coordinates of  $B$  are  $(6, 6)$  and coordinates of  $D$  are  $(1, 5)$ .

Distance between pole  $B$  and  $D$ ,

$$BD = \sqrt{(6-1)^2 + (6-5)^2}$$

$$= \sqrt{5^2 + 1^2}$$

$$= \sqrt{25+1} = \sqrt{26} \text{ units}$$

Thus (d) is correct option.

20. The boiler is essentially a closed vessel inside which water is stored. Fuel is burnt in a furnace and hot gasses are produced. These hot gasses come in contact with water vessel where the heat of these hot gases transfer to the water and consequently steam is produced in the boiler. Then this steam is piped to the turbine of thermal power plant. There are many different types of boiler utilized for different purposes like running a production unit, sanitizing some area, sterilizing equipment, to warm up the surroundings etc.



Rajesh has been given the task of designing a boiler for NTPC. Boiler consist of a cylindrical part in middle and two hemispherical part at its both end. The cross section of boiler is given below. Length of cylindrical part is the 3 times of radius of hemispherical part.

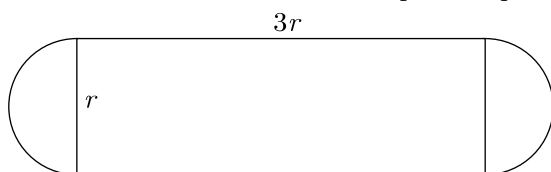

- (i) Which of the following is correct expression for the surface area of cylindrical part of boiler?

- (a)  $2\pi r^2$  (b)  $6\pi r^2$   
(c)  $4\pi r^2$  (d)  $8\pi r^2$



m405

- (ii) Which of the following is correct expression for the total surface area of boiler?

- (a)  $\frac{22}{3}\pi r^2$  (b)  $\frac{11}{3}\pi r^2$   
(c)  $6\pi r^2$  (d)  $10\pi r^2$

- (iii) Which of the following is correct expression for the volume of boiler?

- (a)  $\frac{15}{4}\pi r^3$  (b)  $\frac{19}{3}\pi r^3$   
(c)  $\frac{13}{3}\pi r^3$  (d)  $\frac{17}{4}\pi r^3$

- (iv) What is the ratio of volume to the surface area?

- (a)  $\frac{13}{30}r$  (b)  $\frac{3}{10}r$   
(c)  $\frac{10}{3}r$  (d)  $\frac{3}{10}r$

- (v) If  $r = 3$  m, what is the volume of boiler?

- (a)  $117\pi \text{ m}^3$  (b)  $125\pi \text{ m}^3$   
(c)  $231\pi \text{ m}^3$  (d)  $238\pi \text{ m}^3$

Ans :

- (i) Radius of cylindrical part is equal to the radius of hemispherical part and length of cylindrical part is three times of radius.

Surface area of cylindrical part of boiler =  $2\pi rl$

Since  $l = 3r$ ,  $2\pi rl = 2\pi r \times 3r = 6\pi r^2$

Thus (b) is correct option.

- (ii) Total surface area of boiler

= SA of cylindrical part + SA of two hemisphere

$$= 6\pi r^2 + 2\left(\frac{4\pi r^2}{2}\right)$$

$$= 6\pi r^2 + 4\pi r^2 = 10\pi r^2$$

Thus (d) is correct option.

- (iii) Volume of boiler,

= Volume of cylinder + Volume of two hemisphere

$$= \pi r^2 l + 2\left(\frac{2\pi}{3} \times r^3\right)$$

$$= \pi r^2 \cdot 3r + \frac{4\pi}{3} \times r^3$$

$$= \left(3 + \frac{4}{3}\right)\pi r^3 = \frac{13}{3}\pi r^3$$

Thus (c) is correct option.

- (iv) Ratio of volume to the surface =  $\frac{\frac{13}{3}\pi r^3}{10\pi r^2} = \frac{13}{30}r$

Thus (a) is correct option.

- (v) At  $r = 3$  m volume of boiler,

$$= \frac{13}{3}\pi r^3 = \frac{13}{3} \times \pi \times 3^3$$

$$= 13 \times \pi \times 9 = 117\pi \text{ m}^3$$

Thus (a) is correct option.

## Part - B

All questions are compulsory. In case of internal choices, attempt anyone.

21. Show that  $5\sqrt{6}$  is an irrational number.

Ans :

[Board Term-1 2015]

Let  $5\sqrt{6}$  be a rational number, which can be expressed as  $\frac{a}{b}$ , where  $b \neq 0$ ;  $a$  and  $b$  are co-primes.

Now  $5\sqrt{6} = \frac{a}{b}$   
 $\sqrt{6} = \frac{a}{5b}$



or,  $\sqrt{6} = \text{rational}$   
 But,  $\sqrt{6}$  is an irrational number. Thus, our assumption is wrong. Hence,  $5\sqrt{6}$  is an irrational number.

or

Write the denominator of the rational number  $\frac{257}{500}$  in the form  $2^m \times 5^n$ , where  $m$  and  $n$  are non-negative integers. Hence write its decimal expansion without actual division.

**Ans :** [Board Term-1 2012, NCERT Exemplar]

We have  $500 = 25 \times 20$   
 $= 5^2 \times 5 \times 4$   
 $= 5^3 \times 2^2$



Here denominator is 500 which can be written as  $2^2 \times 5^3$ .

Now decimal expansion,

$$\frac{257}{500} = \frac{257 \times 2}{2 \times 2^2 \times 5^3} = \frac{514}{10^3} = 0.514$$

- 22.** In the figure,  $ABCDE$  is a pentagon with  $BE \parallel CD$  and  $BC \parallel DE$ .  $BC$  is perpendicular to  $CD$ .  $AB = 5$  cm,  $AE = 5$  cm,  $BE = 7$  cm,  $BC = x - y$  and  $CD = x + y$ . If the perimeter of  $ABCDE$  is 27 cm. Find the value of  $x$  and  $y$ , given  $x, y \neq 0$ .

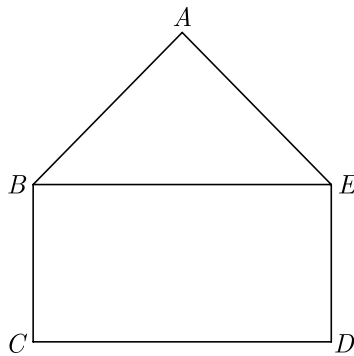

**Ans :** [Board 2020 SQP Standard]

We have redrawn the given figure as shown below.

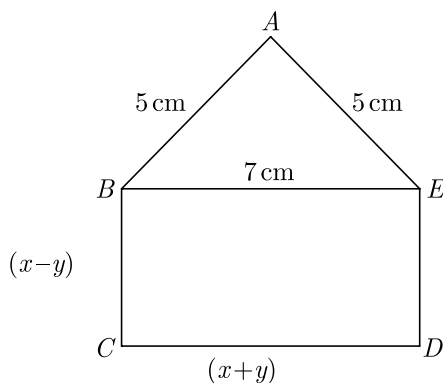

We have  $CD = BE$

$$x + y = 7 \quad \dots(1)$$

Also, perimeter of  $ABCDE$  is 27 cm, thus

$$AB + BC + CD + DE + AE = 27$$

$$5 + (x - y) + (x + y) + (x - y) + 5 = 27$$

$$3x - y = 17 \quad \dots(2)$$

Adding equation (1) and (2) we have

$$4x = 24 \Rightarrow x = 6$$

Substituting  $x = 6$  in equation (1) we obtain

$$y = 7 - x = 7 - 6 = 1$$

Thus  $x = 6$  and  $y = 1$ .

or

Find the values of  $\alpha$  and  $\beta$  for which the following pair of linear equations has infinite number of solutions :  $2x + 3y = 7$ ;  $2\alpha x + (\alpha + \beta)y = 28$ .

**Ans :** [Board Term-1 2011]

We have  $2x + 3y = 7$  and  $2\alpha x + (\alpha + \beta)y = 28$ .

For a pair of linear equations to be consistent and having infinite number of solutions,

$$\frac{a_1}{a_2} = \frac{b_1}{b_2} = \frac{c_1}{c_2}$$

$$\frac{2}{2\alpha} = \frac{3}{\alpha + \beta} = \frac{7}{28}$$

$$\frac{2}{2\alpha} = \frac{7}{28}$$



$$2\alpha \times 7 = 28 \times 2 \Rightarrow \alpha = 4$$

$$\frac{3}{\alpha + \beta} = \frac{7}{28}$$

$$7(\alpha + \beta) = 28 \times 3$$

$$\alpha + \beta = 12$$

$$\beta = 12 - \alpha = 12 - 4 = 8$$

Hence  $\alpha = 4$ , and  $\beta = 8$

- 23.** Find the roots of the quadratic equation  $4x^2 - 4px + (p^2 - q^2) = 0$

**Ans :** [Board Term-2, 2014]

We have  $4x^2 - 4px + (p^2 - q^2) = 0$

Comparing with  $ax^2 + bx + c = 0$  we get

$$a = 4, b = -4p, c = (p^2 - q^2)$$

The roots are given by the quadratic formula,

$$x = \frac{-b \pm \sqrt{b^2 - 4ac}}{2a}$$

$$= \frac{4p \pm \sqrt{16p^2 - 4 \times 4 \times (p^2 - q^2)}}{2 \times 4}$$

$$= \frac{4p \pm \sqrt{16p^2 - 16p^2 + 16q^2}}{8}$$

$$= \frac{4p \pm 4q}{8}$$



Thus roots are  $\frac{p+q}{2}, \frac{p-q}{2}$ .

- 24.** In an equilateral triangle  $ABC$ ,  $AD$  is drawn perpendicular to  $BC$  meeting  $BC$  in  $D$ . Prove that  $AD^2 = 3BD^2$ .

**Ans :** [Board Term-1 2012]

In  $\triangle ABD$ , from Pythagoras theorem,

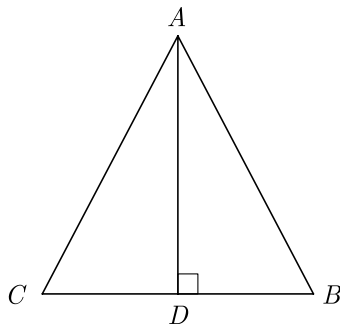

$$AB^2 = AD^2 + BD^2$$

Since  $AB = BC = CA$ , we get

$$BC^2 = AD^2 + BD^2,$$

Since  $\perp$  is the median in an equilateral  $\Delta$ ,  $BC = 2BD$

$$\begin{aligned} (2BD)^2 &= AD^2 + BD^2 \\ 4BD^2 - BD^2 &= AD^2 \\ 3BD^2 &= AD^2 \end{aligned}$$



25. Prove that :  $\frac{\cos A}{1 + \tan A} - \frac{\sin A}{1 + \cot A} = \cos A - \sin A$

Ans : [Board Term-1 2016]

$$\begin{aligned} &\frac{\cos A}{1 + \tan A} - \frac{\sin A}{1 + \cot A} \\ &= \frac{\cos A}{1 + \frac{\sin A}{\cos A}} - \frac{\sin A}{1 + \frac{\cos A}{\sin A}} \\ &= \frac{\cos^2 A}{\cos A + \sin A} - \frac{\sin^2 A}{\sin A + \cos A} \\ &= \frac{\cos^2 A - \sin^2 A}{(\sin A + \cos A)} \\ &= \frac{(\cos A + \sin A)(\cos A - \sin A)}{\sin A + \cos A} \\ &= \cos A - \sin A \quad \text{Hence Proved.} \end{aligned}$$



26. Find the mode of the following distribution :

Classes	25-30	30-35	35-40	40-45	45-50	50-55
Frequency	25	34	50	42	38	14

Ans : Class 35-40 has the maximum frequency 50, therefore this is model class.



Now  $l = 35, f_1 = 50, f_2 = 42, f_0 = 34, h = 5$

$$\begin{aligned} \text{Mode, } M_o &= l + \left( \frac{f_1 - f_0}{2f_1 - f_0 - f_2} \right) h \\ &= 35 + \frac{50 - 34}{100 - 34 - 42} \times 5 \\ &= 35 + \frac{16 \times 5}{24} = 38.33 \end{aligned}$$

27. Prove that  $\sqrt{3}$  is an irrational number.

Ans : [Board 2020 OD Basic]

Assume that  $\sqrt{3}$  is a rational number. Therefore, we can write it in the form of  $\frac{a}{b}$  where  $a$  and  $b$  are co-prime integers and  $q \neq 0$ .

Assume that  $\sqrt{3}$  be a rational number then we have

$$\sqrt{3} = \frac{a}{b},$$

where  $a$  and  $b$  are co-primes and  $b \neq 0$ .

Now  $a = b\sqrt{3}$

Squaring both the sides, we have

$$a^2 = 3b^2$$

Thus 3 is a factor of  $a^2$  and in result 3 is also a factor of  $a$ .

Let  $a = 3c$  where  $c$  is some integer, then we have

$$a^2 = 9c^2$$

Substituting  $a^2 = 3b^2$  we have

$$3b^2 = 9c^2$$

$$b^2 = 3c^2$$

Thus 3 is a factor of  $b^2$  and in result 3 is also a factor of  $b$ .

Thus 3 is a common factor of  $a$  and  $b$ . But this contradicts the fact that  $a$  and  $b$  are co-primes. Thus, our assumption that  $\sqrt{3}$  is rational number is wrong. Hence  $\sqrt{3}$  is irrational.

28. Solve the following pair of equations for  $x$  and  $y$  :

$$\frac{a^2}{x} - \frac{b^2}{y} = 0, \frac{a^2b}{x} + \frac{b^2a}{y} = a + b, \quad x \neq 0; y \neq 0.$$

Ans : [Board Term-1 2011]

We have  $\frac{a^2}{x} - \frac{b^2}{y} = 0$

$$\frac{a^2b}{x} + \frac{b^2a}{y} = a + b = a + b$$

Substituting  $p = \frac{1}{x}$  and  $q = \frac{1}{y}$  in the given equations,

$$a^2p - b^2q = 0 \quad \dots(1)$$

$$a^2bp + b^2aq = a + b \quad \dots(2)$$

Multiplying equation (1), by  $a$

$$a^3p - b^2aq = 0 \quad \dots(3)$$

Adding equation (2) and equation (3),

$$(a^3 + a^2b)p = a + b$$

or,  $p = \frac{(a + b)}{a^2(a + b)} = \frac{1}{a^2}$

Substituting the value of  $p$  in equation (1),

$$a^2\left(\frac{1}{a^2}\right) - b^2q = 0 \Rightarrow q = \frac{1}{b^2}$$

Now,  $p = \frac{1}{x} = \frac{1}{a^2} \Rightarrow x = a^2$

and  $q = \frac{1}{y} = \frac{1}{b^2} \Rightarrow y = b^2$

Hence,  $x = a^2$  and  $y = b^2$

or

Solve for  $x$  and  $y$  :

$$\begin{aligned} ax + by &= \frac{a + b}{2} \\ 3x + 5y &= 4 \end{aligned}$$

Ans : [Board Term-1 2011, Set-44]

We have  $ax + by = \frac{a + b}{2}$

or  $2ax + 2by = a + b \quad \dots(1)$



a231



and  $3x + 5y = 4$

Multiplying equation (1) by 5 we have

$$10ax + 10by = 5a + 5b$$

Multiplying equation (2) by  $2b$ , we have

$$6bx + 10by = 8b$$

Subtracting (4) from (3) we have

$$(10a - 6b)x = 5a - 3b$$

or  $x = \frac{5a - 3b}{10a - 6b} = \frac{1}{2}$

Substitute  $x = \frac{1}{2}$  in equation (2), we get

$$3 \times \frac{1}{2} + 5y = 4$$

$$5y = 4 - \frac{3}{2} = \frac{5}{2}$$

$$y = \frac{5}{2 \times 5} = \frac{1}{2}$$

Hence  $x = \frac{1}{2}$  and  $y = \frac{1}{2}$ .

29.  $\Delta ABC$  is right angled at  $C$ . If  $p$  is the length of the perpendicular from  $C$  to  $AB$  and  $a, b, c$  are the lengths of the sides opposite  $\angle A, \angle B$  and  $\angle C$  respectively, then prove that  $\frac{1}{p^2} = \frac{1}{a^2} + \frac{1}{b^2}$ .

**Ans :** [Board Term-1 2016]

As per given condition we have drawn the figure below.

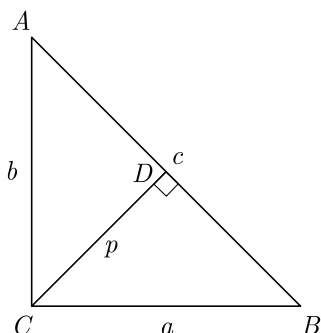

In  $\Delta ACB$  and  $\Delta CDB$ ,  $\angle B$  is common and

$$\angle ABC = \angle CDB = 90^\circ$$

Because of AA similarity we have

$$\Delta ABC \sim \Delta CDB$$

Now  $\frac{b}{p} = \frac{c}{a}$

$$\frac{1}{p} = \frac{c}{ab}$$

$$\frac{1}{p^2} = \frac{c^2}{a^2 b^2}$$

$$\frac{1}{p^2} = \frac{a^2 + b^2}{a^2 b^2} \quad (c^2 = a^2 + b^2)$$

$$\frac{1}{p^2} = \frac{1}{a^2} + \frac{1}{b^2} \quad \text{Hence Proved}$$

or

In  $\Delta ABC, DE \parallel BC$ . If  $AD = x + 2, DB = 3x + 16, AE = x$  and  $EC = 3x + 5$ , then find  $x$ .

**Ans :** [Board Term-1 2015]

...(2)

...(3)

...(4)



As per given condition we have drawn the figure below.

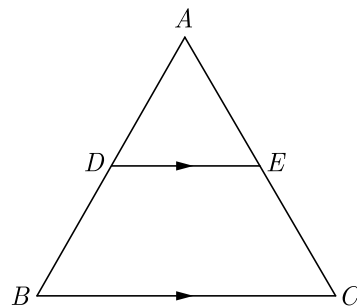

In the give figure

$$DE \parallel BC$$

By BPT we have

$$\frac{AD}{DB} = \frac{AE}{EC}$$

$$\frac{x + 2}{3x + 16} = \frac{x}{3x + 5}$$

$$(x + 2)(3x + 5) = x(3x + 16)$$

$$3x^2 + 5x + 6x + 10 = 3x^2 + 16x$$

$$11x + 10 = 16x$$

$$11x + 10 = 10$$

$$5x = 10 \Rightarrow x = 2$$

30. Prove that :  $2(\sin^6\theta + \cos^6\theta) - 3(\sin^4\theta + \cos^4\theta) + 1 = 0$

**Ans :** [Board 2020 Delhi Standard]

$$\begin{aligned} \text{LHS} &= 2(\sin^6\theta + \cos^6\theta) - 3(\sin^4\theta + \cos^4\theta) + 1 \\ &= 2[(\sin^2\theta)^3 + (\cos^2\theta)^3] - 3(\sin^4\theta + \cos^4\theta) + 1 \\ &= 2[(\sin^2\theta + \cos^2\theta)(\sin^4\theta - \sin^2\theta\cos^2\theta + \cos^4\theta)] + \\ &\quad - 3(\sin^4\theta + \cos^4\theta) + 1 \\ &= 2(\sin^4\theta - \sin^2\theta\cos^2\theta + \cos^4\theta) - 3(\sin^4\theta + \cos^4\theta) + 1 \\ &= 2(\sin^4\theta + \cos^4\theta - \sin^2\theta\cos^2\theta) - 3(\sin^4\theta + \cos^4\theta) + 1 \\ &= -\sin^4\theta - \cos^4\theta - 2\sin^2\theta\cos^2\theta + 1 \\ &= -(\sin^4\theta + \cos^4\theta + 2\sin^2\theta\cos^2\theta) + 1 \\ &= -(\sin^2\theta + \cos^2\theta)^2 + 1 \\ &= -1 + 1 = 0 = \text{RHS} \end{aligned}$$

31. Draw a circle of radius 3 cm. From a point  $P$ , 7 cm away from centre draw two tangents to the circle. Measure the length of each tangent.

**Ans :** [Board Term-2 Foreign 2015]

**Steps of Construction :**

1. Draw a line segment  $PO$  of length 7 cm.
2. Draw a circle with centre  $O$  and radius 3 cm.
3. Draw a perpendicular bisector of  $PO$ . Let  $M$  be the mid-point of  $PO$ .
4. Taking  $M$  as centre and  $OM$  as radius draw a circle. Let this circle intersects the given circle at the point  $Q$  and  $R$ .
5. Join  $PQ$  and  $PR$ . On measuring we get

$$PQ = PR = 6.3 \text{ cm.}$$

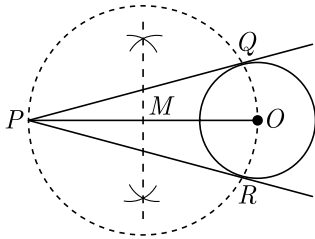

32. A wire when bent in the form of an equilateral triangle encloses an area of  $121\sqrt{3}$  cm<sup>2</sup>. If the wire is bent in the form of a circle, find the area enclosed by the circle. Use  $\pi = \frac{22}{7}$ .

**Ans :** [Board Term-2 OD 2017]

Let  $l$  be length of wire. If it is bent in the form of an equilateral triangle, side of triangle will be  $\frac{l}{3}$ .  
Area enclosed by the triangle,

$$\frac{\sqrt{3}}{4} \times \left(\frac{l}{3}\right)^2 = 121\sqrt{3}$$

$$\frac{1}{4} \times \left(\frac{l}{3}\right)^2 = 121$$

$$\frac{1}{2} \times \frac{l}{3} = 11$$

$$l = 66 \text{ cm}$$

Same wire is bent in the form of circle. Thus circumference of circle will be 66.

$$2\pi r = 66$$

$$r = \frac{66}{2\pi} = \frac{66}{2 \times \frac{22}{7}} = \frac{21}{2}$$

Area enclosed by the circle

$$\pi r^2 = \frac{22}{7} \times \frac{21}{2} \times \frac{21}{2} = \frac{693}{2} = 346.5 \text{ cm}^2$$

33. Compute the median from the following data :

Mid-values	115	125	135	145	155	165	175	185	195
Frequency	6	25	48	72	116	60	38	22	3

**Ans :**

Here, the mid-values are given So, we should first find the upper and lower limits of the various classes. The difference between two consecutive values is  $h = 125 - 115 = 10$

$$\text{Lower limit of a class} = \text{Mid-value} - \frac{h}{2}$$

$$\text{Upper limit} = \text{Mid-value} + \frac{h}{2}$$

Mid-value	Class Groups	Frequency	Cumulative Frequency
115	110-120	6	6
125	120-130	25	31
135	130-140	48	79
145	140-150	72	151
155	150-160	116	267
165	160-170	60	327
175	170-180	38	365
185	180-190	22	387
195	190-200	3	390

Now  $N = 390 ; \frac{N}{2} = 195$

Cumulative frequency just greater than  $\frac{N}{2}$  is 36 and the corresponding class is 150-160. Thus median class is 150-160.

Here,  $l = 150, f = 116, h = 10, F = 151$

$$\begin{aligned} \text{Median, } M_d &= l + \left(\frac{\frac{N}{2} - F}{f}\right)h \\ &= 150 + \frac{195 - 151}{116} \times 10 \\ &= 153.8 \end{aligned}$$



34. If the sum of first  $n$  term of an an AP is given by  $S_n = 3n^2 + 4n$ . Determine the AP and the  $n^{\text{th}}$  term.

**Ans :** [Board Term-2 2014]

Let the first term be  $a$ , common difference be  $d$ ,  $n$ th term be  $a_n$  and sum of  $n$  term be  $S_n$ .

We have  $S_n = 3n^2 + 4n$ .

$$a_1 = 3(1)^2 + 4(1) = 7$$

$$a_1 + a_2 = S_2 = 3(2)^2 + 4(2)$$

$$= 12 + 8 = 20$$

$$a_2 = S_2 - S_1 = 20 - 7 = 13$$

$$a + d = 13$$

or,  $7 + d = 13$

Thus  $d = 13 - 7 = 6$

Hence AP is 7, 13, 19, .....

$$\begin{aligned} \text{Now, } a_n &= a + (n - 1)d \\ &= 7 + (n - 1)(6) \\ &= 7 + 6n - 6 \\ &= 6n + 1 \\ a_n &= 6n + 1 \end{aligned}$$



**or**

The sum of the  $3^{\text{rd}}$  and  $7^{\text{th}}$  terms of an AP is 6 and their product is 8. Find the sum of first 20 terms of the AP.

**Ans :** [Board Term-2 2012]

Let the first term be  $a$ , common difference be  $d$ ,  $n$ th term be  $a_n$  and sum of  $n$  term be  $S_n$ .

We have  $a_3 + a_7 = 6$

$$a + 2d + a + 6d = 6$$

$$a + 4d = 3 \tag{1}$$

and  $a_3 \times a_7 = 8$

$$(a + 2d)(a + 6d) = 8 \tag{2}$$

Substituting the value  $a = (3 - 4d)$  in (2) we get

$$(3 - 4d + 2d)(3 - 4d + 6d) = 8$$

$$(3 + 2d)(3 - 2d) = 8$$

$$9 - 4d^2 = 8$$

$$4d^2 = 1 \Rightarrow d^2 = \frac{1}{4} \Rightarrow d = \pm \frac{1}{2}$$

CASE 1 : Substituting  $d = \frac{1}{2}$  in equation (1),  $a = 1$ .

$$\begin{aligned} S_{20} &= \frac{n}{2}[2a + (n - 1)d] \\ &= \frac{20}{2}\left[2 + \frac{19}{2}\right] = 115 \end{aligned}$$



Thus  $d = \frac{1}{2}$ ,  $a = 1$  and  $S_{20} = 115$

CASE 2 : Substituting  $d = -\frac{1}{2}$  in equation (1)  $a = 5$

$$S_{20} = \frac{20}{2} \left[ 2 \times 5 + 19 \times \left(-\frac{1}{2}\right) \right]$$

$$= 10 \left[ 10 - \frac{19}{2} \right] = 15$$

Thus  $d = -\frac{1}{2}$ ,  $a = 5$  and  $S_{20} = 15$

35. If  $A(-2, 1)$ ,  $B(a, 0)$ ,  $C(4, b)$  and  $D(1, 2)$  are the vertices of a parallelogram  $ABCD$ , find the values of  $a$  and  $b$ . Hence find the lengths of its sides.

**Ans :** [Board 2018]

As per information given in question we have drawn the figure below.

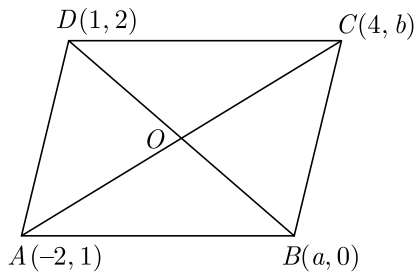

Here  $ABCD$  is a parallelogram and diagonals  $AC$  and  $BD$  bisect each other. Therefore mid point of  $BD$  is same as mid point of  $AC$ .

$$\left(\frac{a+1}{2}, \frac{2}{2}\right) = \left(\frac{-2+4}{2}, \frac{b+1}{2}\right)$$

$$\frac{a+1}{2} = 1 \Rightarrow a = 1$$

and  $\frac{b+1}{2} = 1 \Rightarrow b = 1$

Now  $AB = \sqrt{(x_2 - x_1)^2 + (y_2 - y_1)^2}$

$$= \sqrt{(1+2)^2 + (0-1)^2}$$

$$= \sqrt{9+1} = \sqrt{10} \text{ unit}$$
 $BC = \sqrt{(x_2 - x_1)^2 + (y_2 - y_1)^2}$ 

$$= \sqrt{(4-1)^2 + (1-0)^2}$$

$$= \sqrt{9+1} = \sqrt{10} \text{ unit}$$

Since  $ABCD$  is a parallelogram,

$$AB = CD = \sqrt{10} \text{ unit}$$

$$BC = AD = \sqrt{10} \text{ unit}$$

Therefore length of sides are  $\sqrt{10}$  units each.

36. Distance between two ships is 73.2 m. From the top of tower, 100 m high, a man observes two cars on the opposite sides of the tower with the angles of depression  $30^\circ$  and  $45^\circ$  respectively. Find the distance between the cars. (Use  $\sqrt{3} = 1.73$ )

**Ans :** [Board Term-2 SQP 2016]

Let  $DC$  be tower of height 100 m.  $A$  and  $B$  be two car on the opposite side of tower. As per given in question we have drawn figure below.

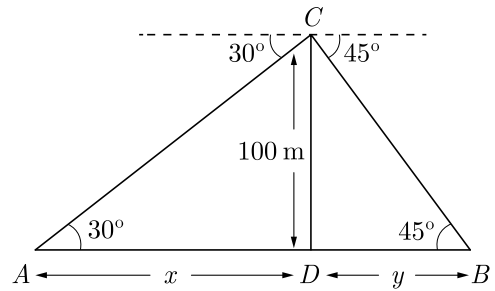

In right  $\triangle ADC$ ,

$$\tan 30^\circ = \frac{CD}{AD}$$

$$\frac{1}{\sqrt{3}} = \frac{100}{x}$$

$$x = 100\sqrt{3}$$



i148

...(1)

In right  $\triangle BDC$ ,

$$\tan 45^\circ = \frac{CD}{DB}$$

$$1 = \frac{100}{y} \Rightarrow y = 100 \text{ m}$$

Distance between two cars

$$AB = AD + DB = x + y$$

$$= (100\sqrt{3} + 100)$$

$$= (100 \times 1.73 + 100) \text{ m}$$

$$= (173 + 100) \text{ m}$$

$$= 273 \text{ m}$$

Hence, distance between two cars is 273 m.

WWW.CBSE.ONLINE

Download unsolved version of this paper from [www.cbse.online](http://www.cbse.online)